

STS SERIES INSTALLATION



CAUTION: Top rail must be installed into wall blocking.
Do not attempt to support with drywall anchors only.

Phone: 800-441-9692 | www.pdqlocks.com

STS 171-78 Series Slider

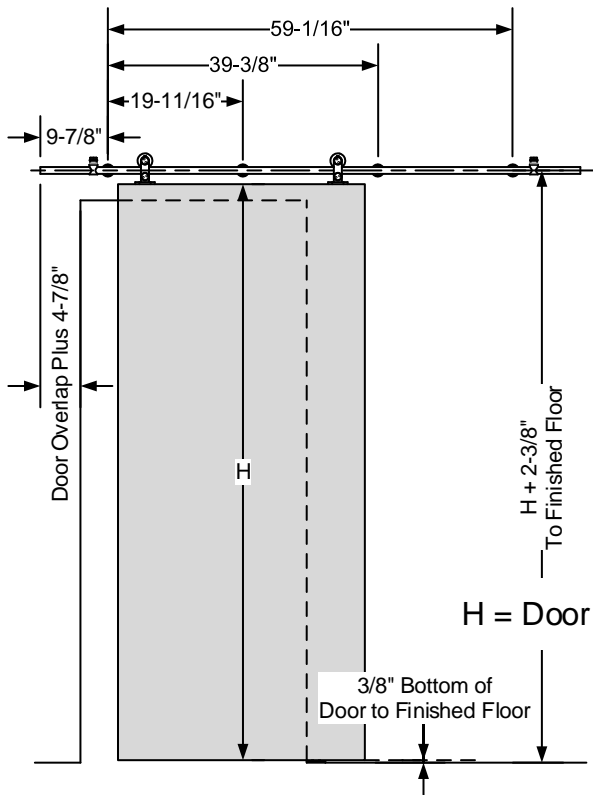

STS 171-98 Series Slider

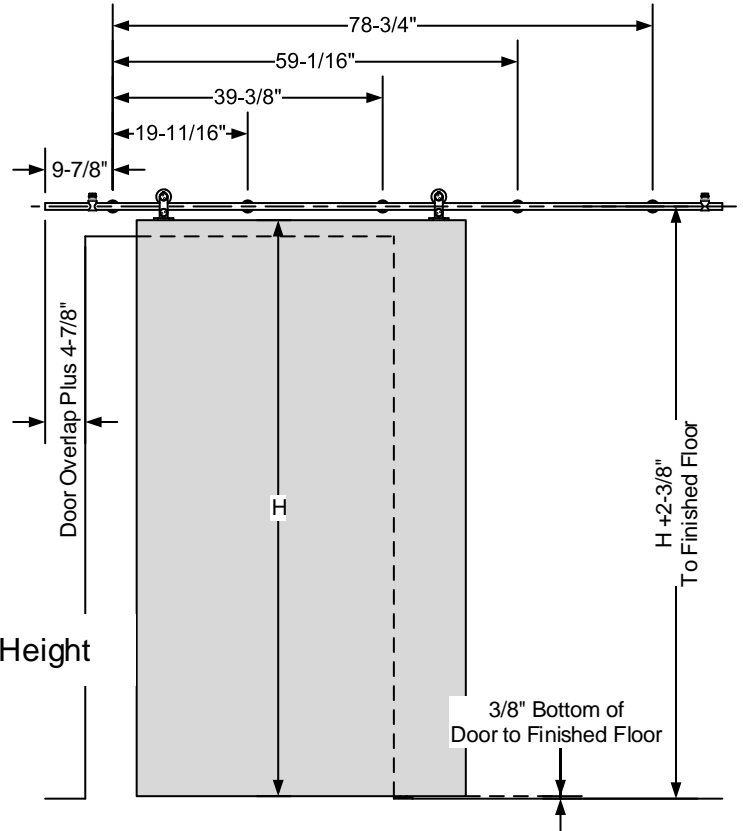

H = Door Panel Height

Tools Required

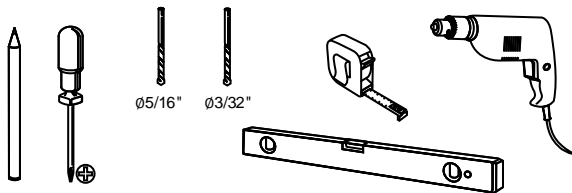

Included In Package

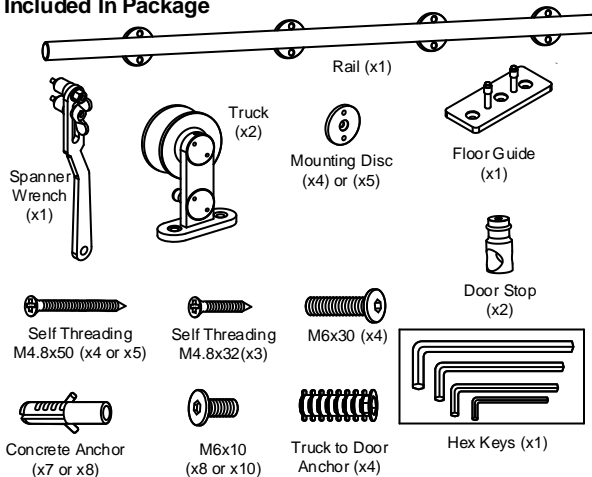

INSTALLATION OVERVIEW:

1. It is assumed closed door is centered on the opening. Determine door overlap on leading edge of door. Door overlap should be at least 2" on floor guide side.

Measure/mark locations of rail mounting posts on wall using dimensions and formulas shown above. Ensure mounting holes are LEVEL.

Drill holes, fasten rail mounting discs to wall.

2. Fasten rail to mounting discs and install door stops over ends of rail.

3. Locate floor guide on finished floor. Guide is located flush with edge of opening and 2" from wall to centerline.

4. Route slot in bottom of door to act as a track for the floor guide.

5/6. Remove anti-jump pin from back of each truck. Mark/drill on top of door panel for truck (x2). Secure truck with anchors as shown.

7/8. Place door on track, re-install anti-jump pins.

9. Adjust position of door stops for open and closed positions.

1. INSTALL MOUNTING DISCS

- **RAIL MUST BE INSTALLED INTO WALL BLOCKING**
- Mark wall for mounting discs with dimensions from first page of this instruction. It is critical that the mounting rail is **LEVEL**.
- Using 3/32" bit, drill rail mounting holes.
- Secure discs with included screw.

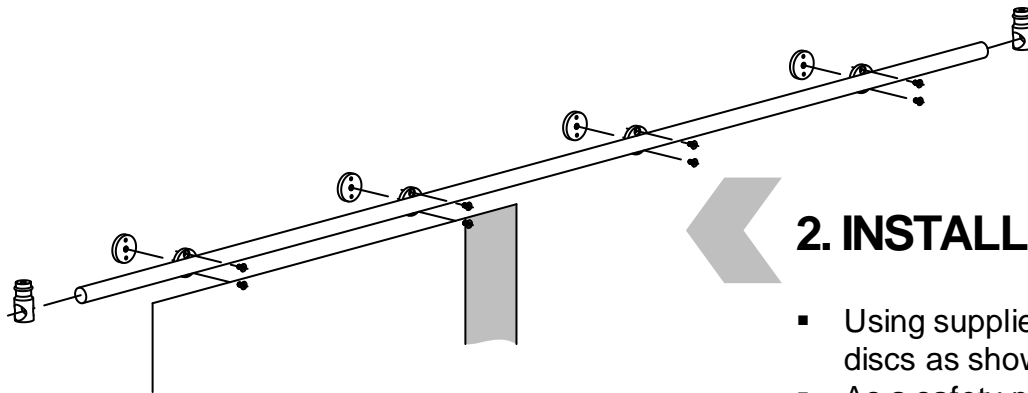
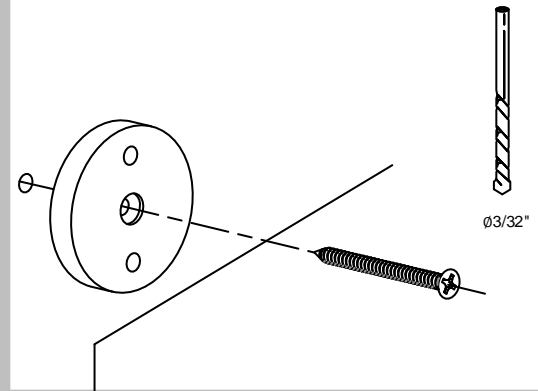

2. INSTALL RAIL ONTO WALL

- Using supplied screws, attach rail to mounting discs as shown.
- As a safety precaution, install door stops over each end of rail and secure using supplied hex key.

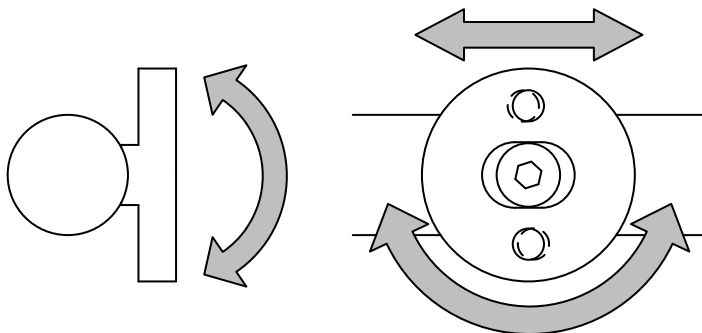

Rail Foot Adjustment

Mounting feet on rail are adjustable. Loosening screw on back of foot allows for rotational and side to side adjustment for alignment with wall mounted discs.

3. INSTALL FLOOR GUIDE

- Locate and mark holes for floor guide. Guide should be flush with edge of opening and 2" from center of guide to wall (**NOT TO TRIM**).
- Drill (3) 5/16" holes in floor.
- Install supplied concrete anchors into floor and attach guide with included screws.

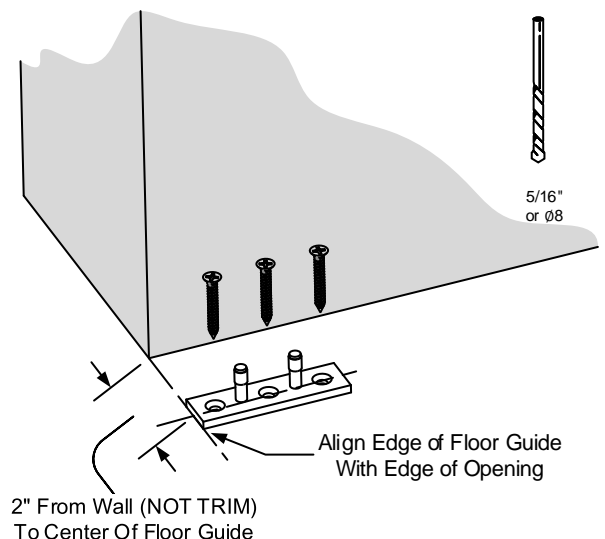

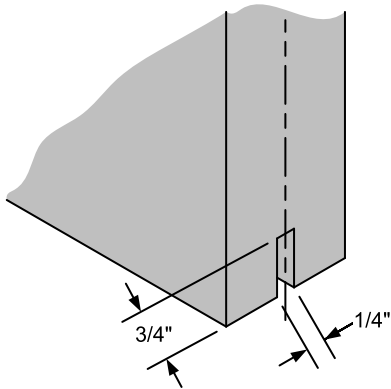

4. ROUTE DOOR FOR GUIDE

- Route slot in bottom of door for floor guide 1/4" wide and 3/4" deep.



5. PREPARE TRUCKS FOR MOUNTING

- Remove cap from truck with included spanner wrench.
- Using provided hex key, remove screw and anti-jump finger.

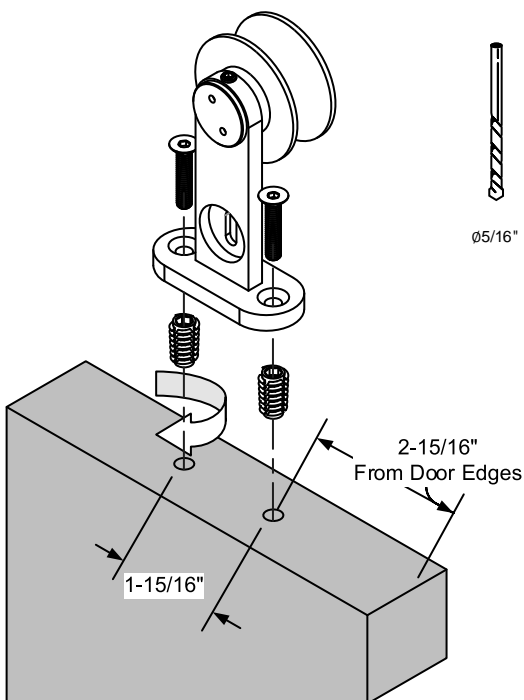
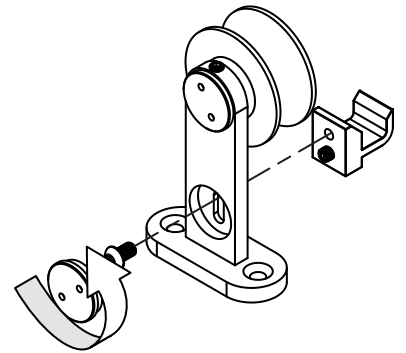

6. ATTACH TRUCKS TO DOOR

- Drill 5/16" holes, 1" deep in top of door panel.
- Using supplied 6mm hex key, install anchors into door.
- Using provided 4mm hex key, install (2) included M6x30 flathead screws on each truck.

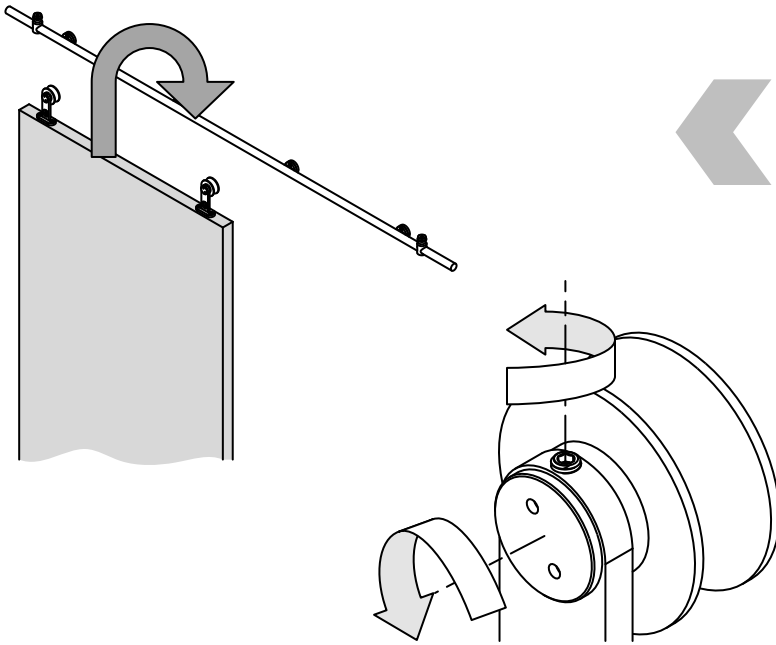

7. HANG DOOR

- Hang door on rail.
- Check to ensure door is plumb. If not plumb, loosen cap with spanner wrench and adjust set screw on top of truck assemblies.

8. RE-INSTALL ANTI-JUMP FINGERS

- Re-install anti-jump fingers and covers before testing door. Anti-jump fingers should be installed close to bottom of rail, but not so close that they rub on the rail during operation.

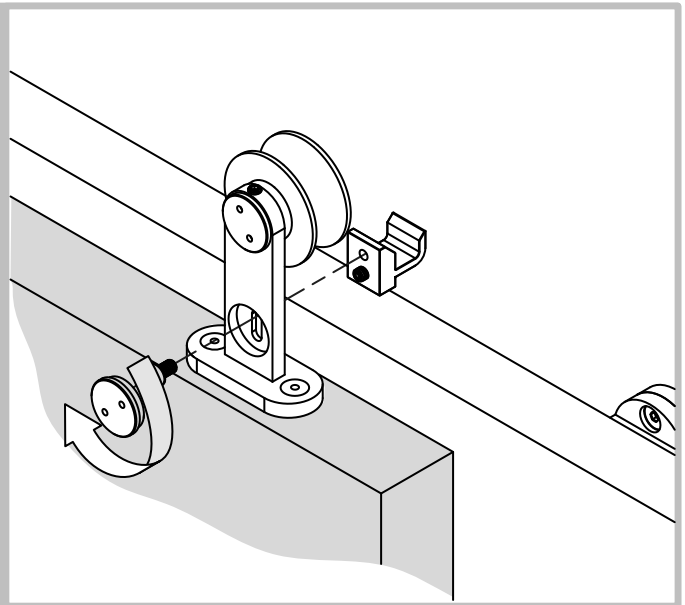

9. ADJUST DOOR STOPS

- Adjust stops for both open and closed door panel positions. Tighten stops once desired position is achieved.
- Restrict door travel to ensure door panel does not disengage from floor guide.

