

Installation Instructions For GT, XGT Cylindrical Lever Locksets GRADE 1

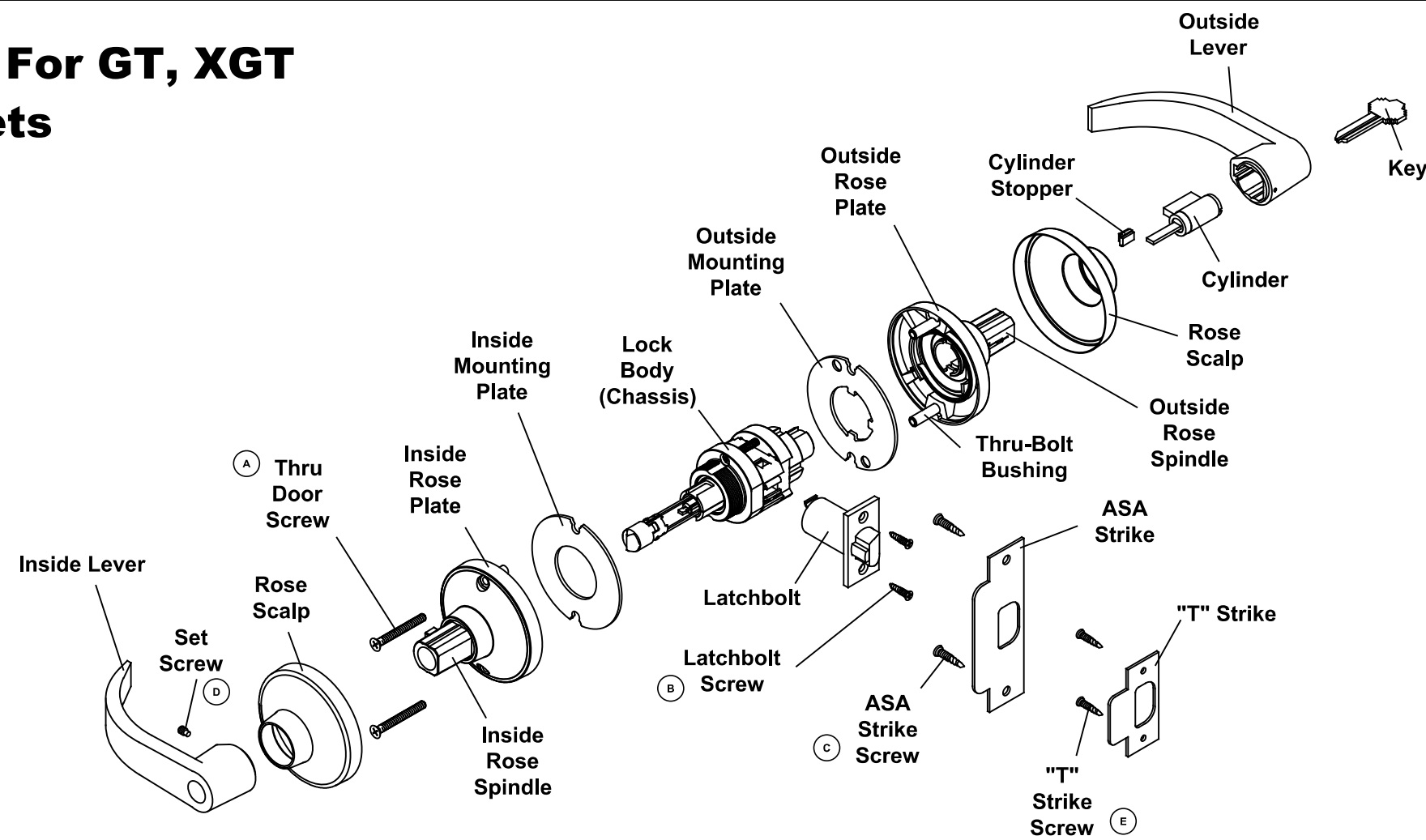

2754 Creek Hill Rd.
Leola, PA 17540
800-441-9692
Fax: 717-656-6892
www.pdqlocks.com

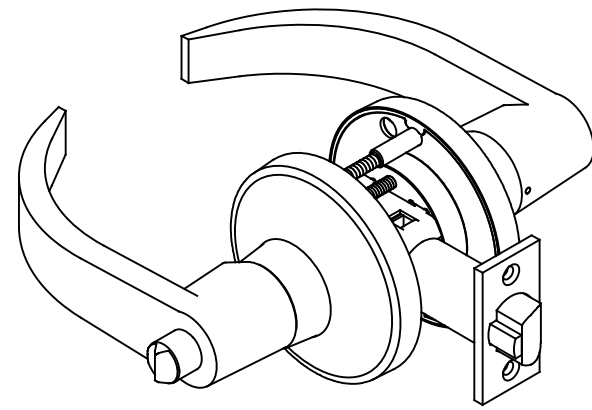

HARDWARE SCHEDULE

- A. 2 - M5 x 0.8, L=60mm
- B. 2 - #8-32 COMBO
- C. 2 - #12-24 COMBO
- D. 1 - M5 x 0.8 FULL DOG, L=8mm
- E. 2 - #8-32 COMBO

VA10034
REV 2

ADJUST FOR DOOR THICKNESS

NOTE: Lock is preset for 1 3/4" doors unless otherwise specified.

Adjust inside mounting plate as follows:

- A. Remove inside trim.
- B. Use template to gauge location of the inside mounting plate for the desired door thickness. Thread mounting plate to the correct location.

FOR FUNCTIONS WITH BUTTONS, ADJUST PUSH BUTTON AS FOLLOWS:

- A. Squeeze button support.
- B. Adjust button to the correct door thickness
 - (1) First position is for 2" and 2 1/4" doors.
 - (2) Second position is for 1 3/4" doors.

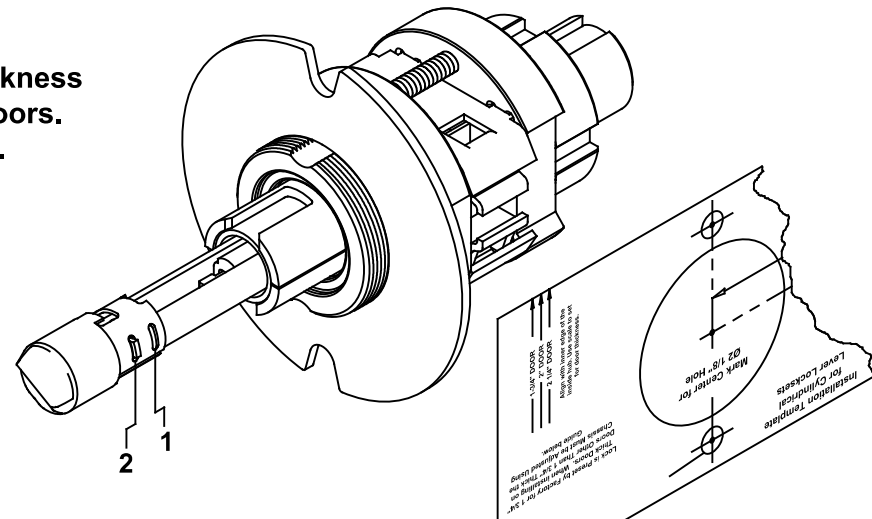

STANDARD CYLINDER

TO REMOVE CYLINDER LEVER

- A. Insert key into lock and rotate 45° clockwise.
- B. Depress retainer clip with pick provided (or other pointed tool).
- C. Pull lever off of lock.

TO INSTALL CYLINDER LEVER

- A. Slide lever down to lever retainer clip on spindle.
- B. Insert key into cylinder and rotate 45° clockwise.
- C. Push in lever retainer clip and slide lever into locked position.

TO REMOVE CYLINDER FROM LEVER

- A. Remove cylinder stopper.
- B. Slide cylinder out of lever.

TO INSTALL CYLINDER INTO LEVER

- A. Slide cylinder into lever.
- B. Install cylinder stopper.

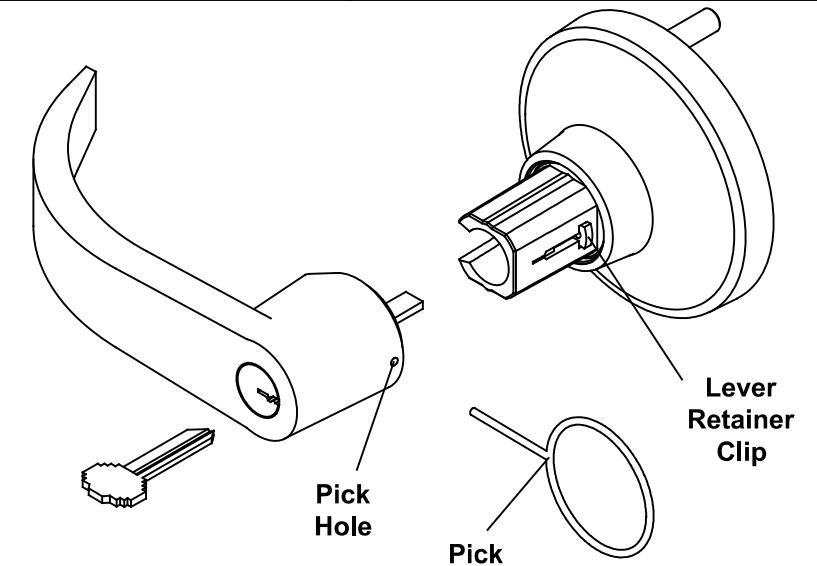

IC CYLINDER

TO REPLACE CYLINDER

- A. Insert control key, turn clockwise and pull to remove cylinder.
- B. Remove tailpiece and spacer spring (only used on 6 pin cylinders) from back of old cylinder and install on new cylinder.
- C. Insert control key into new cylinder, turn clockwise and insert cylinder into lever.
- D. Rotate key counter-clockwise to lock cylinder into place and remove key.

1. MARK DOOR

- Mark height line on edge of door. Suggested height from floor is 38" to 40 5/16".
- Fold template over edge of door, centering on the height line.
- Mark center point for 2 1/8" hole.
- Mark thru door holes for two 5/16" holes.

NOTE: Accurate door preparation is essential for proper function of this lock.

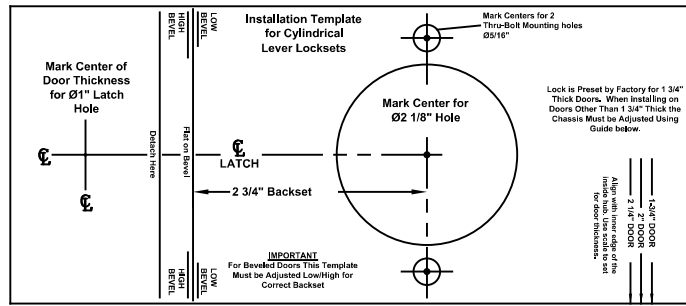

4. INSTALL STRIKE

- Mark a vertical center line on the door jamb.
- Mark an intersecting height line opposite the center of the latch hole.
- Bore a 1" hole on vertical line in jamb, 1" deep, to allow the latchbolt to extend to its full length.
- Cut out for strike using the strike as a template.
- Install the strike using the two combo screws provided in the strike pack.

NOTE: "ASA" strike installation shown. For "T" strike or "full lip" strike follow the same procedure.
A mortar box may be installed between the strike and the jamb.

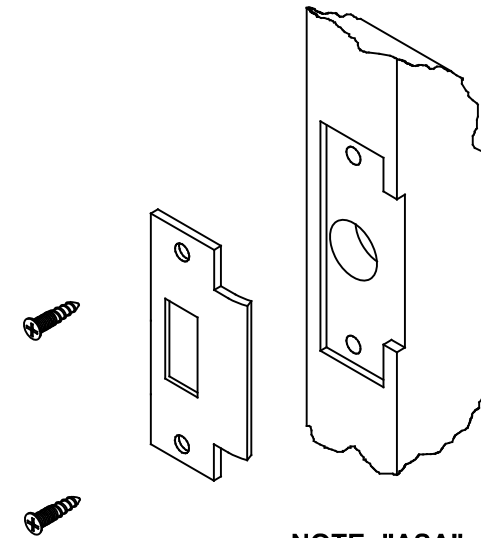

2. BORE HOLES (DOOR PREPARATION)

- Bore a 2 1/8" hole through door.
- Bore two 5/16" holes (thru bolt holes) through door.
- Bore a 1" hole to intersect the center line of the 2 1/8" hole. Cut out for the 1 1/8" x 2 1/4" latch front. Use the latch front faceplate as a template. Latch front should sit flush with the edge of the door.

NOTE: A fixture is recommended for drilling the thru bolt holes.

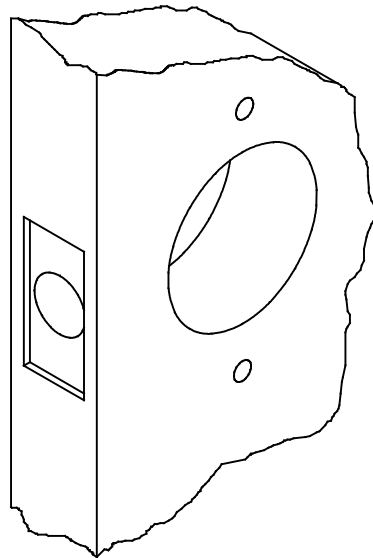

5. INSTALL LOCK ASSEMBLY

- Remove outside trim and mounting plate.
- Insert lock chassis into the door from the inside, making sure that the lock body engages with the latch prongs and the retractor interlocks with latch "T" bar.

NOTE: Lock is preset by factory for 1 3/4" doors. For installation on a door other than 1 3/4", see "HOW TO ADJUST FOR DOOR THICKNESS" on reverse.

CAUTION!
DO NOT ATTEMPT TO INSTALL LOCK UNIT WITH DOOR CLOSED, GUARD BOLT TAILPIECE WILL INTERFERE.

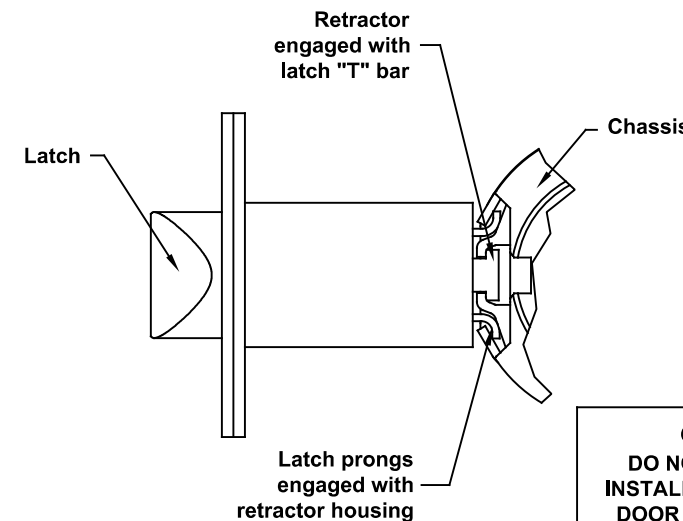

3. INSTALL LATCHBOLT

- Use the two #8-32 combo screws provided.

NOTE: Make sure latchbolt is facing the correct side of the door.

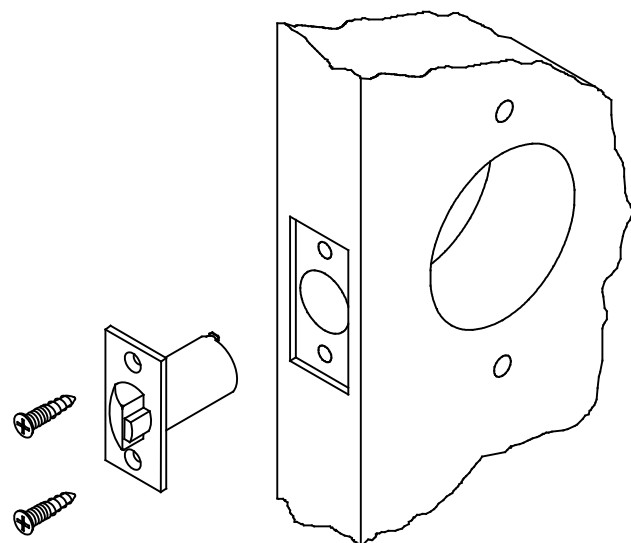

6. INSTALL TRIM ASSEMBLIES

- Install outside mounting plate and trim.
- Install inside trim.
- Install two thru door screws (M5 x 0.8 x 60mm) into the thru bolt bushings of the outside trim.
- Install the inside rose scalp, making sure that the tabs on the rose scalp snap firmly into the cutouts on the rose plate.
- Install inside lever and tighten the set screw. For cylinder lever installation see reverse.

